

# FlexLink S9E-88

## Extended L-Band Switch Matrix 8:8 (fan-out/distributive)

The FlexLink S9E-88 represents a professional 8:8 L-Band Switch Matrix (fan-out/distributive) designed in a compact and space-saving 1RU/19" rack-mount chassis available with RF coax I/O connectors as well as with optical inputs.

The FlexLink S9E-88 is a future proof L-Band Switch Matrix supporting extended L-Band frequency 850...2450MHz, making it a perfect solution also for KA-Band and HTS applications. The unit features an efficient, flexible and reliable solution for today's and future L-Band signal management and allows to switch/route any input to any or all outputs without limitations and interferences, while all combinations of inputs and outputs are configurable locally and remotely.

The FlexLink S9E-88 supports variable gain adjustment, slope-equalization, RF power monitoring, Threshold monitoring/alarming, as well as 1:1 redundant dual power-supply. Furthermore, the unit features switchable LNB-supply and a 10MHz external reference signal input. Isolation, linearity and frequency response are at the highest level assuring excellent and stable operation with superior RF performance and signal quality. The units come with various coaxial RF connectors for the inputs and outputs and can be equipped with optical inputs as well.

The FlexLink S9E-88 has a LC-Display & keypads for user-friendly local configuration. Remote configuration and monitoring can be done via its Ethernet-Interface (<http://WebGUI>, SNMP) while it can also be integrated into a management and control system (NMS or M&C) via SNMP.

The FlexLink S9E-88 is an ideal platform for flexible signal switching applications and perfectly suited for integration into Teleports, Satellite Earth Stations, DSNG's as well as Broadcasting and CATV/IPTV headend architectures.

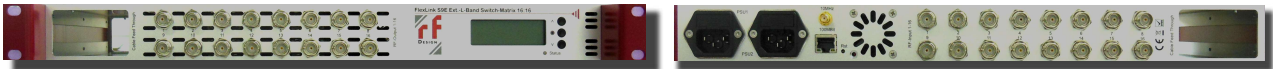

Product image may vary from its original

### FEATURES & BENEFITS

- Space saving 1RU/19" modular design
- Professional switching solution with 8:8 I/O configuration (inputs rear / outputs front)
- Also available with optical inputs (upon request)\*
- Variable gain adjustment (@ any input)
- L-Band Slope equalization 0...9dB (@ any input)\*\*
- RF power monitoring (@ any input)
- Threshold monitoring/alarming
- Switchable LNB supply 13/15/18V, 22kHz (@ any input) 400mA current monitoring, 450mA alarm shutdown\*\*
- Features 10MHz external reference input (@ any input)\*\*
- Front side LC-Display & keypads for local configuration
- Front side Ethernet-Interface for remote configuration (<http://WebGUI>, SNMPv2c)
- Low power-consumption & heat generation
- Superior RF performance, signal quality and stability
- Admin & User login protection
- 1:1 redundant dual power supply

\*upon request / \*\*not available when equipped with optical inputs

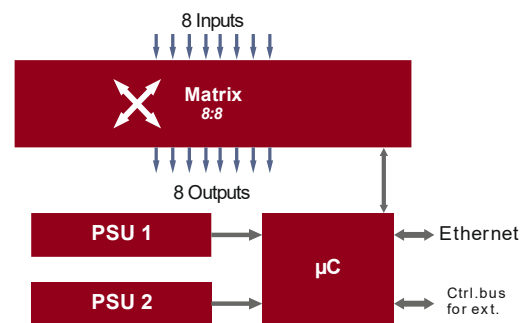

# FlexLink S9E-88

## Extended L-Band Switch Matrix 8:8 (fan-out/distributive)

### TECHNICAL SPECIFICATIONS

|                                    |  |
|------------------------------------|--|
| ➤ <b>Dimensions:</b>               | 1RU/19" rack-mount, Weight approx. 6kgs.                               |
| ➤ <b>Switching Configuration:</b>  | 8:8 I/O's (inputs front side / outputs rear side)                      |
| ➤ <b>Power supply:</b>             | 85...230V, 50/60Hz (1:1 redundant, hot swappable)                      |
| ➤ <b>Power consumption</b>         | <25W (without LNB-supply)  |
| ➤ <b>Frequency range:</b>          | Extended L-Band 850...2450MHz  |
| ➤ <b>I/O connectors:</b>           | 75Ohm F(f), 75Ohm BNC(f); 50Ohm SMA(f), 50Ohm BNC(f)*, optical SC/APC* |
| ➤ <b>10MHz external input**:</b>   | 50Ohm SMA(f), rear side**  |
| ➤ <b>Variable gain control:</b>    | -20dB...+10dB, 1dB steps (@any input)                                  |
| ➤ <b>Slope equalization**:</b>     | 0...9dB, 1dB steps (@any input)**                                      |
| ➤ <b>RF Input power:</b>           | -10dBm, 0dBm max.*   |
| ➤ <b>Output IP1:</b>               | +3dBm  |
| ➤ <b>Max. RF output power:</b>     | +5dBm max.   |
| ➤ <b>Input/Output Return loss:</b> | 14dB typ.  |
| ➤ <b>Isolation:</b>                | Input/Input ≥60dB – Output/Output ≥60dB – Input/Output ≥60dB           |
| ➤ <b>Noise figure:</b>             | >10dB typ., ± 1dB / 24dB typ., ± 1dB (@ full gain) w. optical inputs*  |
| ➤ <b>Frequency response:</b>       | ± 1dB typ. ± 1,5dB max. in L-Band / ± 3dB max. in extended L-Band*     |
| ➤ <b>RF power monitoring:</b>      | 60dB dynamic range (@ any input)                                       |
| ➤ <b>Input level control:</b>      | Monitoring threshold adjustment/alarming                               |
| ➤ <b>IMA3 @ -10dBm:</b>            | > -56dBc @-10dBm   |
| ➤ <b>Switchable LNB-supply**:</b>  | 13/15/18V/22kHz, 390mA, 400mA max. (@ any input)**                     |
| ➤ <b>Local configuration:</b>      | LC-Display/keypads   |
| ➤ <b>Remote configuration:</b>     | RJ45 100Mbit Ethernet-Interface (WebGUI, SNMPv2c)                      |
| ➤ <b>Environmental:</b>            | ETSI En300, Part 1-3, Class 3.1  |
| ➤ <b>EMC / Safety:</b>             | EN 50083-2 / EN 60950-10°C...45°C                                      |
| ➤ <b>Operating temperature:</b>    | 0°C...45°C   |
| ➤ <b>Storage temperature:</b>      | -10°C...65°C   |
| ➤ <b>Humidity:</b>                 | 90%, non-condensing  |
| ➤ <b>RoHS:</b>                     | Compliant  |

\*upon request / \*\*not available when equipped with optical inputs

### OPTICAL SPECIFICATIONS (variants with optical inputs)

|                                   |   |
|-----------------------------------|---|
| ➤ <b>Fiber type:</b>              | Single mode 9/125   |
| ➤ <b>Optical input connector:</b> | SC/APC  |
| ➤ <b>Operating wavelength:</b>    | 1310 – 1560nm   |
| ➤ <b>Optical input level:</b>     | -10dBm (min. optical sensitivity) to +10dBm max. (damage level) |
| ➤ <b>SFDR:</b>                    | -107dBc/Hz typ.   |

### ORDER INFORMATION

| Type                  | Short Description                  | I/O connectors                       |
|-----------------------|------------------------------------|--------------------------------------|
| FlexLink S9E-88-75F   | 8:8 Switch Matrix, extended L-Band | 75Ohm F(f)                           |
| FlexLink S9E-88-75B   | 8:8 Switch Matrix, extended L-Band | 75Ohm BNC(f)                         |
| FlexLink S9E-88-50S   | 8:8 Switch Matrix, extended L-Band | 50Ohm SMA(f)                         |
| FlexLink S9E-88-50B*  | 8:8 Switch Matrix, extended L-Band | 50Ohm BNC(f)*                        |
| FlexLink S9E-88-F50S* | 8:8 Switch Matrix, extended L-Band | Optical In SC/APC; 50Ohm SMA(f) Out* |
| FlexLink S9E-88-F50B* | 8:8 Switch Matrix, extended L-Band | Optical In SC/APC; 50Ohm BNC(f) Out* |
| FlexLink S9E-88-F75B* | 8:8 Switch Matrix, extended L-Band | Optical In SC/APC; 75Ohm BNC(f) Out* |
| FlexLink S9E-88-F75F* | 8:8 Switch Matrix, extended L-Band | Optical In SC/APC; 75Ohm F(f) Out*   |

\*upon request / \*\*not available when equipped with optical inputs